

## ELECTRIC TWO-TERM LEVEL CONTROLLERS ERH-...-06

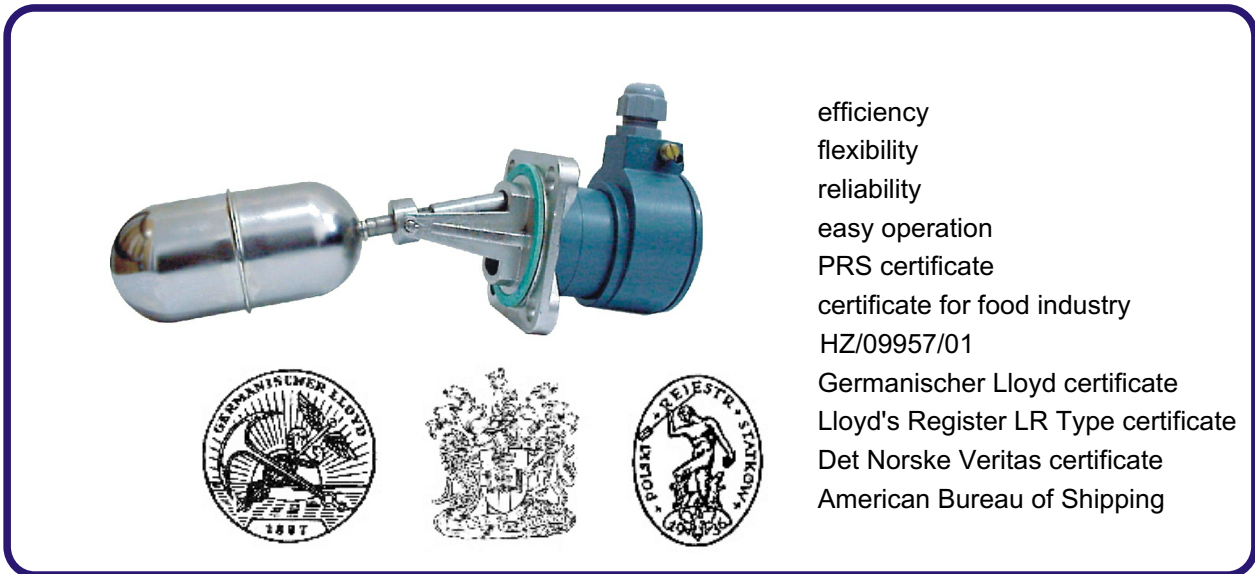

efficiency  
 flexibility  
 reliability  
 easy operation  
 PRS certificate  
 certificate for food industry  
 HZ/09957/01  
 Germanischer Lloyd certificate  
 Lloyd's Register LR Type certificate  
 Det Norske Veritas certificate  
 American Bureau of Shipping

THE LEVEL CONTROLLERS IN MARINE VERSION ARE DESIGNED FOR SIGNALLING OF LIQUID LIMIT LEVELS OR TWO-TERM LIQUID LEVEL CONTROL IN OPEN AND CLOSED PRESSURIZED TANKS, IN NON-EXPLOSIVE ATMOSPHERE. THE CONTROLLERS CAN OPERATE ON SHIPS IN MARINE CLIMATE. THE UNITS ARE PROVIDED WITH CERTIFICATES ISSUED BY PRS, PZH, GERMANISCHER LLOYD, LLOYD'S REGISTER, DNV, ABS. THE CONTROLLERS CAN OPERATED IN AGGRESSIVE LIQUIDS NOT REACTING ON 1H18N9T STEEL.

### TECHNICAL DATA

Parameters	ERH-01-06	ERH-02-06	ERH-03-06	ERH-04-06
Measuring range	10; 20; 30mm	10; 20; 30mm	100...400mm 50...250mm	32...1,350mm
Repeatability	±15%	±15%	±15%; ±5%	±15%; ±2%
Mass	2 kg	2.2 kg	2.4 kg	3.3 kg
Static pressure of the medium	4 MPa			1.6 MPa
Permissible temperature of the medium	250°C	200°C	250°C	
Ambient temperature	-25°C...+70°C			
Casing protection degree	IP 56			
Minimum liquid density	0.6 x 10 <sup>-3</sup> kg/cm <sup>3</sup>			

### ELECTRIC PARAMETERS OF MICROSWITCH:

Rated voltage AC 400V, 50Hz; or 220V DC  
 Minimal voltage and switching current 10V; 20mA

SWITCHING VOLTAGE [V]	DC VOLTAGE		AC VOLTAGE	
	Switching current [A]	Switching durability	Switching current [A]	Switching durability
48	4.0	0.06 x 10 <sup>6</sup>	9.0	0.1 x 10 <sup>6</sup>
110	1.0			
220	0.6			
400	X	X		

Cross sections of connecting wires - for single-core wires: 1...2.5 sq. mm  
 - for multile-core wires: 0.75...1.5 sq. mm

## DIMENSIONED DRAWINGS

ERH-01-06

CODE	Hmm	Lmm
- 1	120	190
- 2	140	230
- 3	150	255

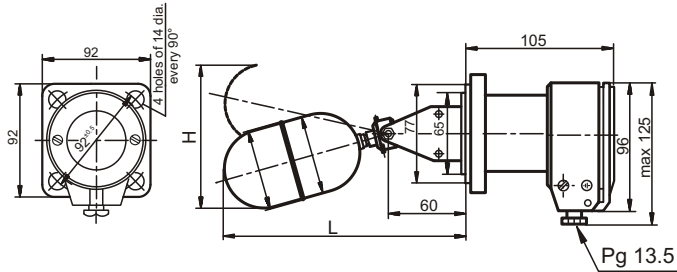

ERH-02-06

CODE	Hmm	Lmm
- 1	120	190
- 2	140	230
- 3	150	255

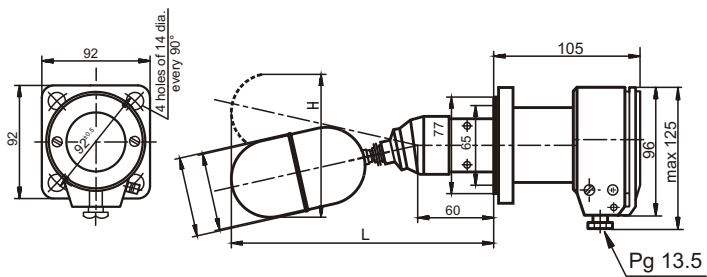

ERH-04-06

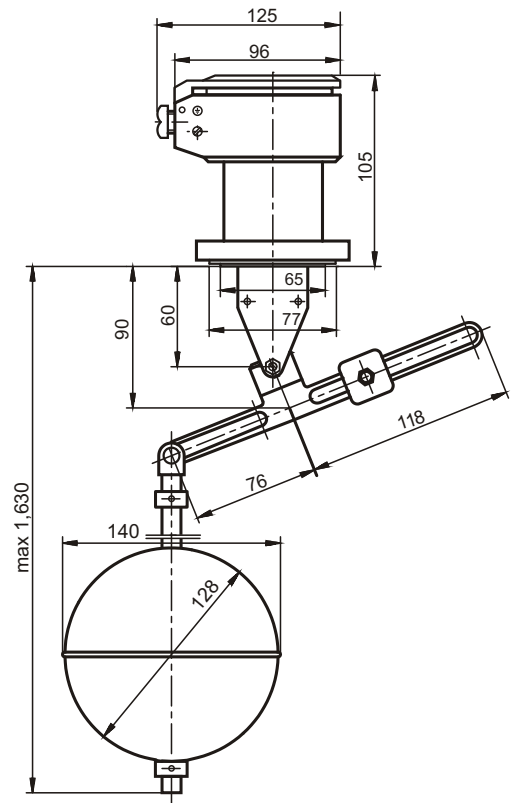

ERH-03-06

CODE	Hmm	Lmm
- 1	680	510
- 2	450	380

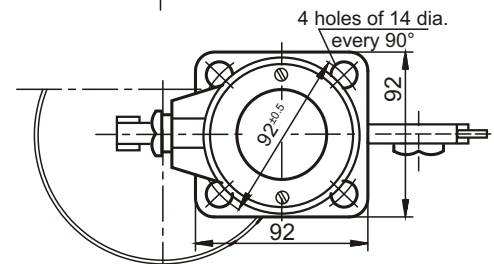
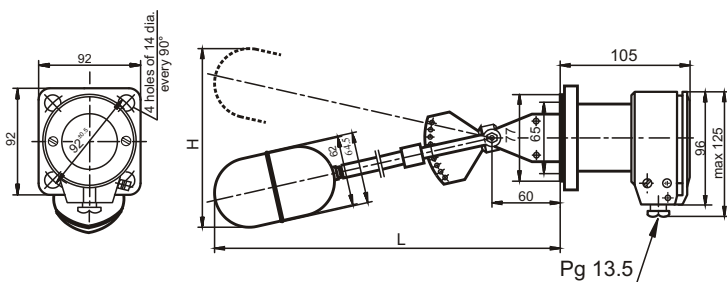

ERH-01-06-4-1

Electric two-term level controller  
with curved tube dimensions: A=185, B=80

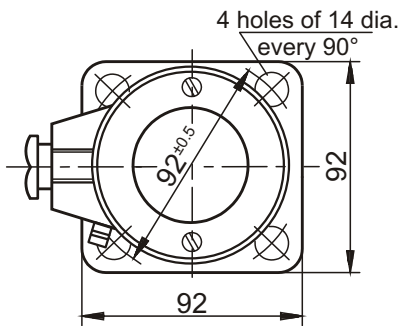
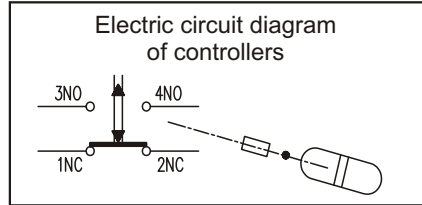
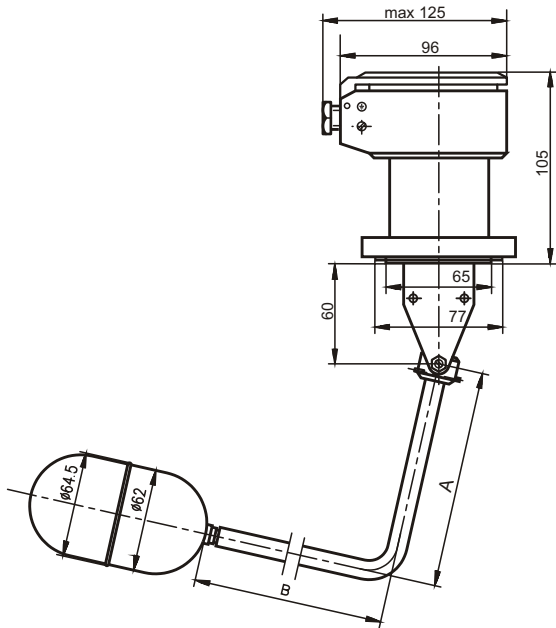

EXAMPLE OF CONNECTING STUB PIPE

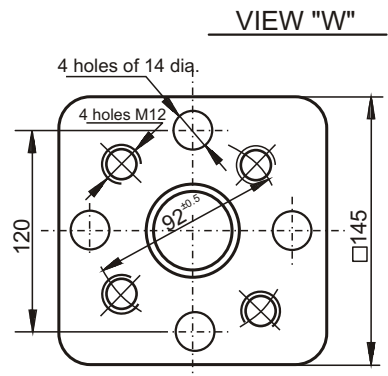
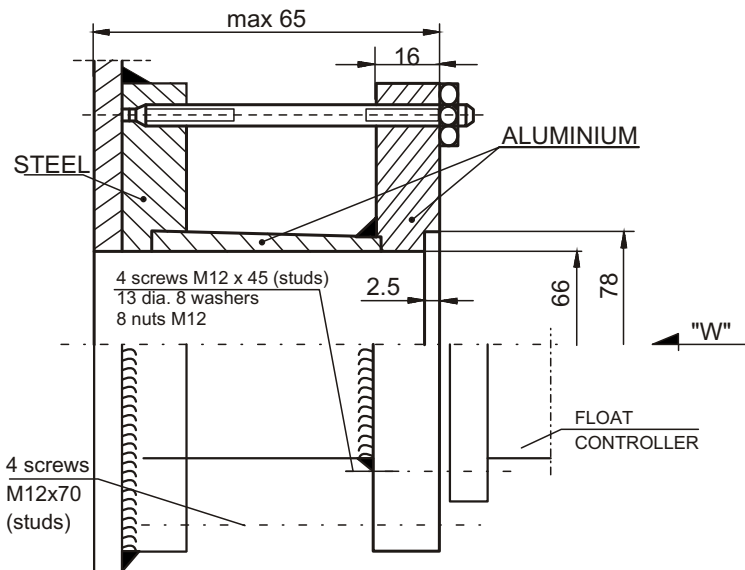

### ORDERING OF ERH-01-06 CONTROLLER

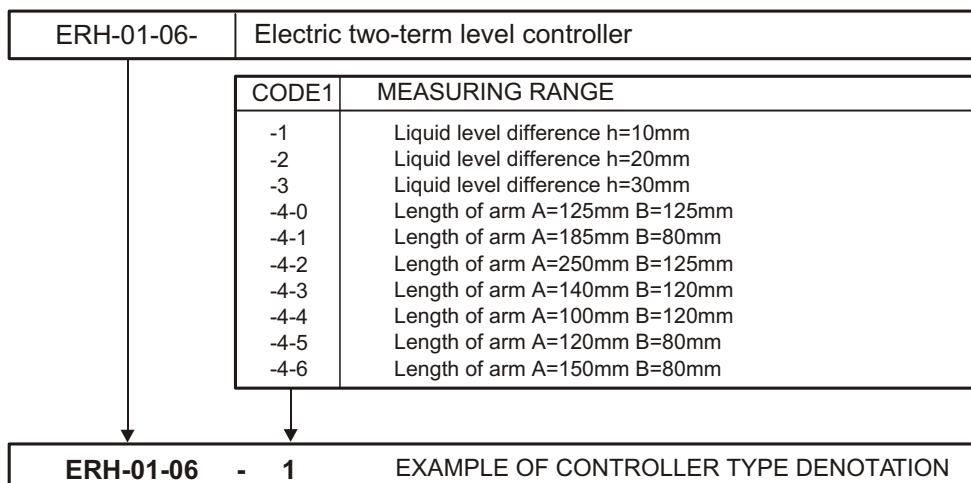

### ORDERING OF ERH-02-06 CONTROLLER

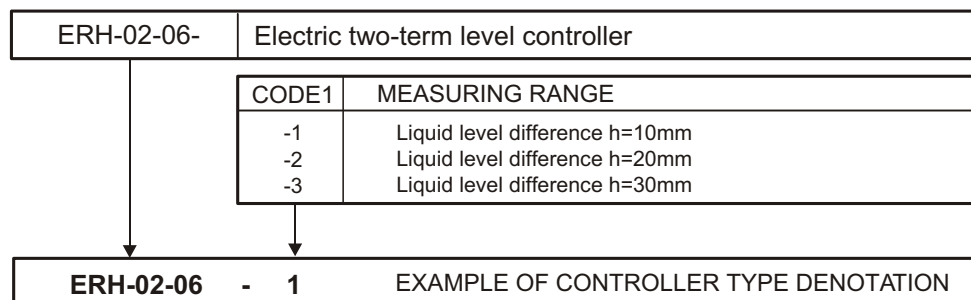

### ORDERING OF ERH-03-06 CONTROLLER

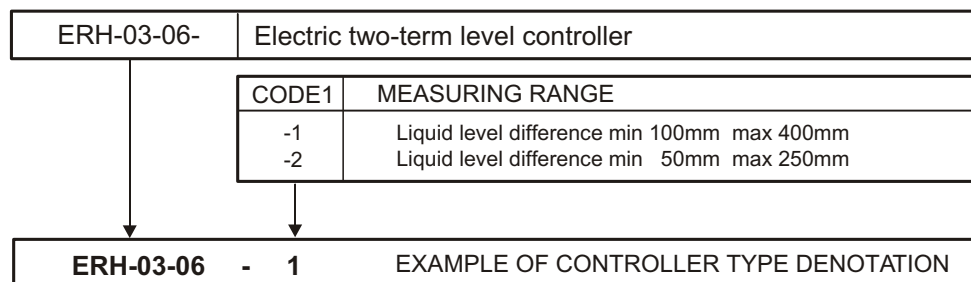

### ORDERING OF ERH-04-06 CONTROLLER

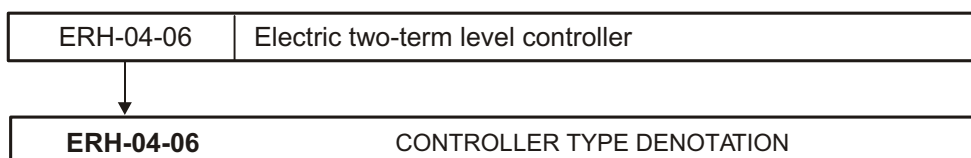

- One should place the following data in the order:
- controller type and Product Directory SWW 0918-239,
  - kind of controlled medium,
  - parameters,
  - measuring range.

The right of introducing design changes in the product, without deteriorating of its operation parameters, is reserved.